

# Regulatory Information Report

**RIRF24073**

**Fire resistance test for penetrations through  
the horizontal separating element**

Client: Agnitek Pty Ltd

Test method: AS1530.4-2014

Report Date: 15/07/2024

Test number: PF24073



# Table of Contents

1.1	Document revision schedule .....	3
1.2	Signatories .....	3
2.	Report Summary.....	4
3.	General Information .....	5
3.1	Testing Scope .....	5
3.2	Contact Details.....	5
3.3	Specimen Preparation, Conditioning and Timeline .....	6
3.4	Use of the Report.....	6
4.	Specimen Description.....	8
4.1	Supporting Construction.....	8
4.2	Specimens .....	8
5.	Test Results.....	11
5.1	Specimen 1 .....	11
5.2	Specimen 2 .....	13
5.3	Specimen 3 .....	15
5.4	Specimen 4 .....	17
5.5	Specimen 5 .....	19
5.6	Specimen 6 .....	21
5.7	Specimen 7 .....	23
5.8	Specimen 8 .....	25
5.9	Specimen 9 .....	27
6.	Observations during the test.....	29
7.	Photos .....	30
7.1	Photos before and after the test.....	30

## 1.1 Document revision schedule

Revision #	Date	Description
1	15/07/2024	Issued to Client

## 1.2 Signatories

Report	Name	Signature	Date
Prepared by:	Alexey Kokorin		15/07/2024
Authorised by:	Andrew Bain (Authorized signatory)		15/07/2024



All tests reported herein have been performed in accordance with the laboratory's scope of accreditation

## 2. Report Summary

---

Service penetration was tested passing through a 120mm (nominal) concrete slab.

Specimen #	Service	Actual Integrity (min)	Actual Insulation (min)	FRL
1	DN40 PVC-U DWV Pipe	124 NF	124 NF	-/120/120
2	DN50 PVC-U DWV Pipe	124 NF	124 NF	-/120/120
3	DN65 PVC-U DWV Pipe	124 NF	124 NF	-/120/120
4	DN80 PVC-U DWV Pipe	124 NF	124 NF	-/120/120
5	DN100 PVC-U DWV Pipe	124 NF	124 NF	-/120/120
6	DN32 PVC-U DWV Pipe	124 NF	124 NF	-/120/120
7	90mm SDR 11 S PPR pipe	124 NF	124 NF	-/120/120
8	90mm SDR 9 MF PPR pipe	124 NF	124 NF	-/120/120
9	40mm SDR 11 S PPR pipe	124 NF	124 NF	-/120/120

**NF – No failure during the test**

## 3. General Information

---

### 3.1 Testing Scope

**Applicable Standards:**

AS 1530.4-2014 Section 10: Service penetrations and control joints

AS 4072.1-2005 (r. 2016) Components for the protection of openings in fire-resistant separating elements. Part 1: Service penetrations and control joints

**Departures from Testing Method:**

No departures from the testing method

**Test conditions:**

Conditions complied with the Standard.

### 3.2 Contact Details

**Accredited testing laboratory**

Fire TS Lab - Passive Fire Inspection and Test Services Ltd

Accreditation Number - 1335

1/113 Pavilion Drive, Mangere, Auckland, 2022

New Zealand

Contact e-mail: [tests@firelab.co.nz](mailto:tests@firelab.co.nz)

**Client/Applicant:**

Agnitek Pty Ltd

8 Clare St, Bayswater, VIC, 3153

Australia

Contact e-mail: [info@agnitek.com.au](mailto:info@agnitek.com.au)

**Manufacturer:**

Same as Client/Applicant

### 3.3 Specimen Preparation, Conditioning and Timeline

#### **Specimens conditioning and delivery to Laboratory:**

Separating element was built by the Laboratory in line with Client instructions. Installation of fire stopping system was performed by the Laboratory in line with Client instructions. The Laboratory was not involved in sampling of the materials. The Laboratory verified materials during construction of the specimen. All specimens were capped on fire side only.

#### **Testing date:**

10/6/2024

#### **Installation completion date:**

6/6/2024

#### **Termination of The Test:**

The test was discontinued at 124 minutes.

### 3.4 Use of the Report

A regulatory information report was issued in addition to the full test report PF24073. This provides the minimum information required for regulatory compliance.

This report shall not be reproduced, except in full.

The specimen was an asymmetrical construction. The results of the test apply if exposed to fire as tested.

This report details the methods of construction, test conditions and the results obtained when the specific element of construction described herein was tested following the procedure outlined in AS 1530.4. Any significant variation with respect to size, constructional details, loads, stresses, edge or end conditions, other than that allowed under the field of direct application in the relevant test method, is not covered by this report.

Because of the nature of fire resistance testing and the consequent difficulty in quantifying the uncertainty of measurement of fire resistance, it is not possible to provide a stated degree of accuracy of the result.

The test results relate to the specimens of the product in the form in which they were tested. Differences in the composition or thickness of the product may significantly affect the performance during the test and may therefore invalidate the test results. Care should be taken to ensure that any product, which is supplied or used, is fully represented by the specimens, which were tested.

The specimens were supplied by the sponsor and the Laboratory was not involved in any of selection or sampling procedures.

The results of these fire tests may be used to directly assess fire hazard, but it should be recognized that a single test method will not provide a full assessment of fire hazard under all fire conditions.

## 4. Specimen Description

### 4.1 Supporting Construction

Separating element		
1.1	Item	120mm concrete slab
	Dimensions	Width / Height (W/H): 1400mm x 1400mm
		Wall Thickness (T): 120mm

### 4.2 Specimens

Services		
2.1	Item / Product Name	DN40 PVC-U DWV Pipe
	Dimensions	Inner Diameter (ID): 38mm
		Outer Diameter (OD): 43mm
		Thickness (T): 2mm
2.2	Item / Product Name	DN50 PVC-U DWV Pipe
	Dimensions	Inner Diameter (ID): 51mm
		Outer Diameter (OD): 56mm
		Thickness (T): 2.5mm
2.3	Item / Product Name	DN65 PVC-U DWV Pipe
	Dimensions	Inner Diameter (ID): 63mm
		Outer Diameter (OD): 69mm
		Thickness (T): 3mm
2.4	Item / Product Name	DN80 PVC-U DWV Pipe
	Dimensions	Inner Diameter (ID): 76mm
		Outer Diameter (OD): 82.5mm
		Thickness (T): 3mm
2.5	Item / Product Name	DN100 PVC-U DWV Pipe
	Dimensions	Inner Diameter (ID): 104mm
		Outer Diameter (OD): 110mm
		Thickness (T): 3mm



2.6	Item / Product Name	DN32 PVC-U DWV Pipe
	Dimensions	Inner Diameter (ID): 32mm
		Outer Diameter (OD): 36mm
		Thickness (T): 2mm
2.7	Item / Product Name	90mm SDR 11 S PPR pipe
	Dimensions	Inner Diameter (ID): 72mm
		Outer Diameter (OD): 90mm
		Thickness (T): 9mm
2.8	Item / Product Name	90mm SDR 9 MF PPR pipe
	Dimensions	Inner Diameter (ID): 68mm
		Outer Diameter (OD): 90mm
		Thickness (T): 11mm
2.9	Item / Product Name	40mm SDR 11 S PPR pipe
	Dimensions	Inner Diameter (ID): 32mm
		Outer Diameter (OD): 40mm
		Thickness (T): 4mm

### Sealants

3.1	Item / Product Name	AGNI-Seal
	Dimensions	600mL Sausage
	Installation	Sealed gaps from unexposed side

### Fixings

4.1	Item / Product Name	AGNI-Strap - Stainless Steel ties
	Dimensions	Width / Height (W/H): 4.6mm x 200mm
	Installation	Used to fix AGNI-Sleeve around service
4.2	Item / Product Name	AGNI-CLIP - Stainless Steel Clips
	Installation	Used to fix AGNI-Sleeve to separating element
4.3	Item	Masonry Anchor
	Dimensions	30mm x 6mm

	Installation	Used to fix AGNI-Sleeve to separating element
--	--------------	---

Intumescent		
9.1	Item	AGNI-Sleeve
	Dimensions	Width (W): 170mm
		Thickness (T): 3.5mm
	Installation	Installed around service

## 5. Test Results

### 5.1 Specimen 1

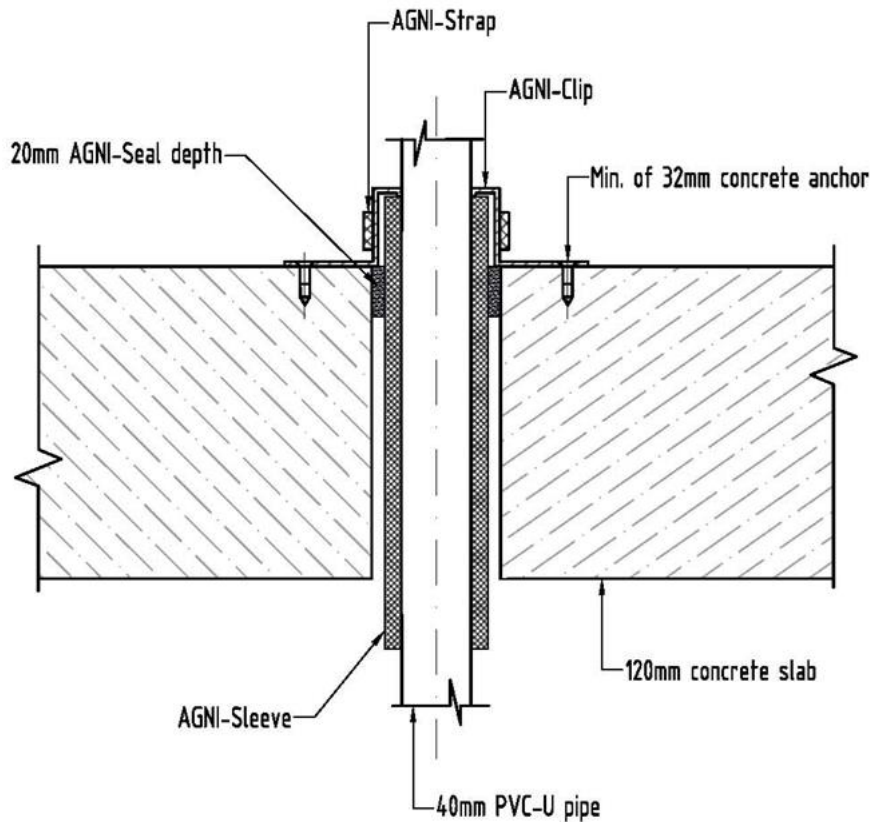

**Figure 3 – Specimen 1**

Service penetration details	
Service	DN40 PVC-U DWV Pipe
Service Support	Unistrut structure at 525mm and 1525mm
Aperture Diameter	57mm
Annular Spacing	Min: 6mm, Max: 8mm

Local Fire-stopping system	
Application	Asymmetrical
System description	AGNI-Sleeve positioned in annular space against the aperture perimeter with no overlap, extended 25mm from separating element. The Sleeve was secured by a cable tie penetrated the Sleeve and fixed with 2 screws and 2 clips on the unexposed

	side of separating element. AGNI-Seal sealed any gap between pipe, AGNI-Sleeve and separating element, from unexposed side of separating element.
--	---

**Test results**

Structural adequacy	Not applicable
Integrity	No failure at 124 minutes
Insulation	No failure at 124 minutes



## 5.2 Specimen 2

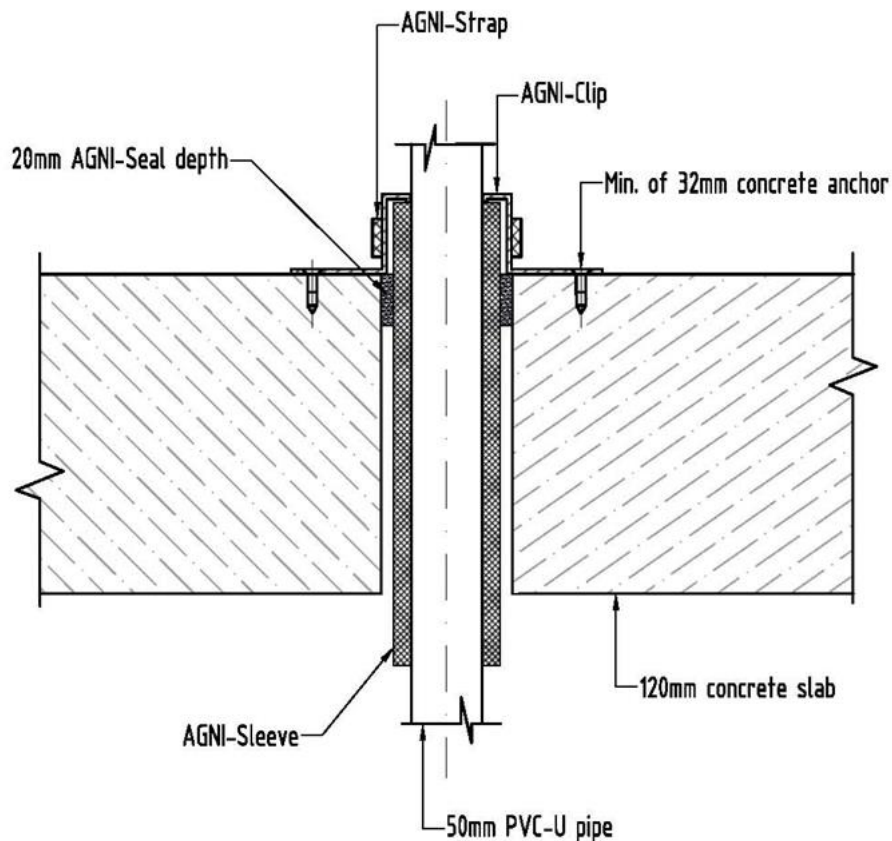

**Figure 5 – Specimen 2**

Service penetration details	
Service	DN50 PVC-U DWV Pipe
Service Support	Unistrut structure at 525mm and 1525mm
Aperture Diameter	86mm
Annular Spacing	Min: 14mm, Max: 16mm

Local Fire-stopping system	
Application	Asymmetrical
System description	AGNI-Sleeve positioned in annular space against the aperture perimeter with no overlap, extended 25mm from separating element. The Sleeve was secured by a cable tie penetrated the Sleeve and fixed with 2 screws and 2 clips on the unexposed side of separating element. AGNI-Seal sealed any gap

	between pipe, AGNI-Sleeve and separating element, from unexposed side of separating element.
--	--

---

**Test results**

---

Structural adequacy	Not applicable
Integrity	No failure at 124 minutes
Insulation	No failure at 124 minutes



### 5.3 Specimen 3

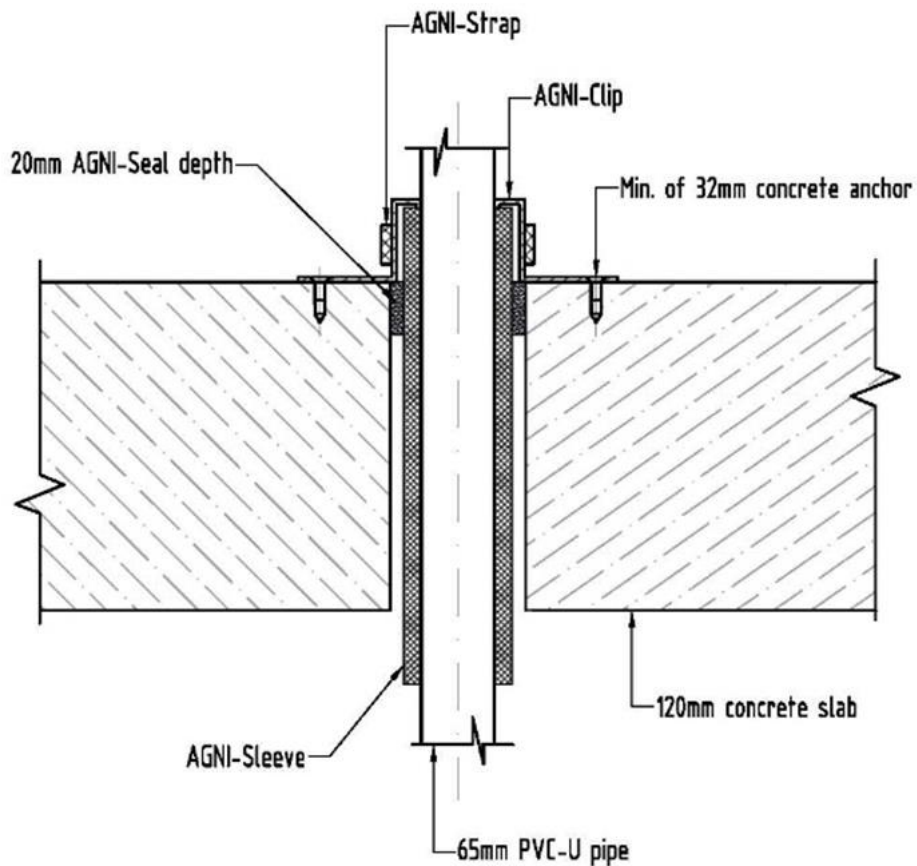

Figure 7 – Specimen 3

Service penetration details	
Service	DN65 PVC-U DWV Pipe
Service Support	Unistrut structure at 525mm and 1525mm
Aperture Diameter	85mm
Annular Spacing	Min: 7mm, Max: 9mm

Local Fire-stopping system	
Application	Asymmetrical
System description	AGNI-Sleeve positioned in annular space against the aperture perimeter with no overlap, extended 25mm from separating element. The Sleeve was secured by a cable tie penetrated the Sleeve and fixed with 2 screws and 2 clips on the unexposed side of separating element. AGNI-Seal sealed any gap

	between pipe, AGNI-Sleeve and separating element, from unexposed side of separating element.
--	--

---

**Test results**

Structural adequacy	Not applicable
Integrity	No failure at 124 minutes
Insulation	No failure at 124 minutes





## 5.4 Specimen 4

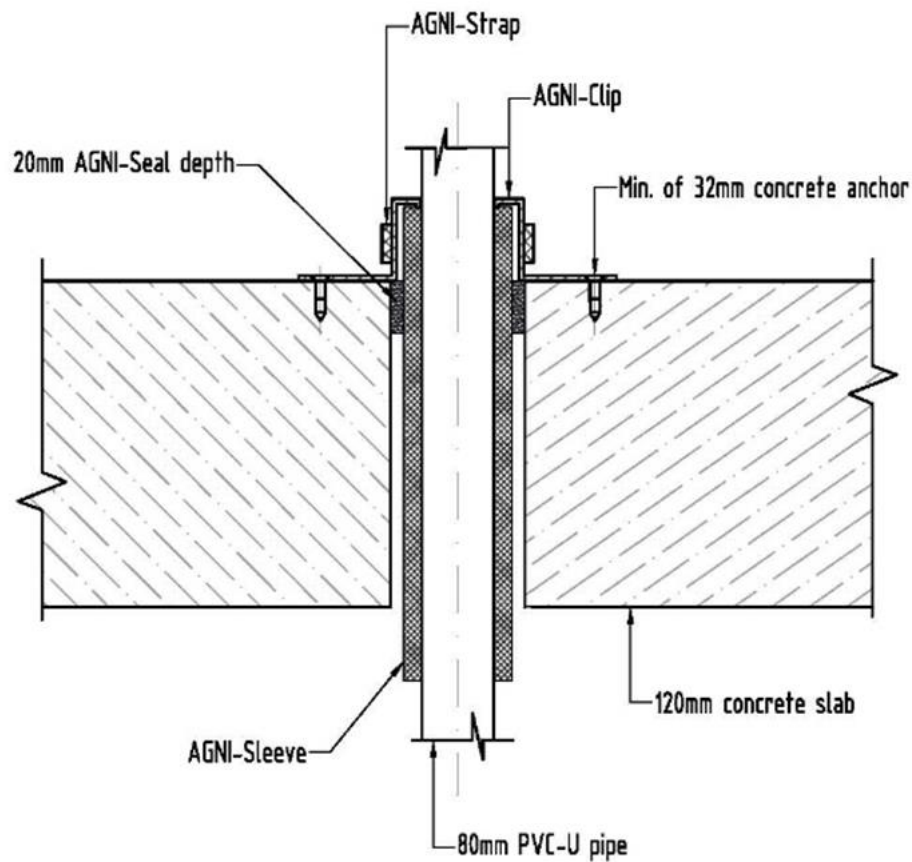

**Figure 9 – Specimen 4**

Service penetration details	
Service	DN80 PVC-U DWV Pipe
Service Support	Unistrut structure at 525mm and 1525mm
Aperture Diameter	102mm
Annular Spacing	Min: 8.5, Max: 11mm

Local Fire-stopping system	
Application	Asymmetrical
System description	AGNI-Sleeve positioned in annular space against the aperture perimeter with no overlap, extended 25mm from separating element. The Sleeve was secured by a cable tie penetrated the Sleeve and fixed with 2 screws and 2 clips on the unexposed side of separating element. AGNI-Seal sealed any gap

	between pipe, AGNI-Sleeve and separating element, from unexposed side of separating element.
--	--

---

**Test results**

---

Structural adequacy	Not applicable
Integrity	No failure at 124 minutes
Insulation	No failure at 124 minutes



## 5.5 Specimen 5

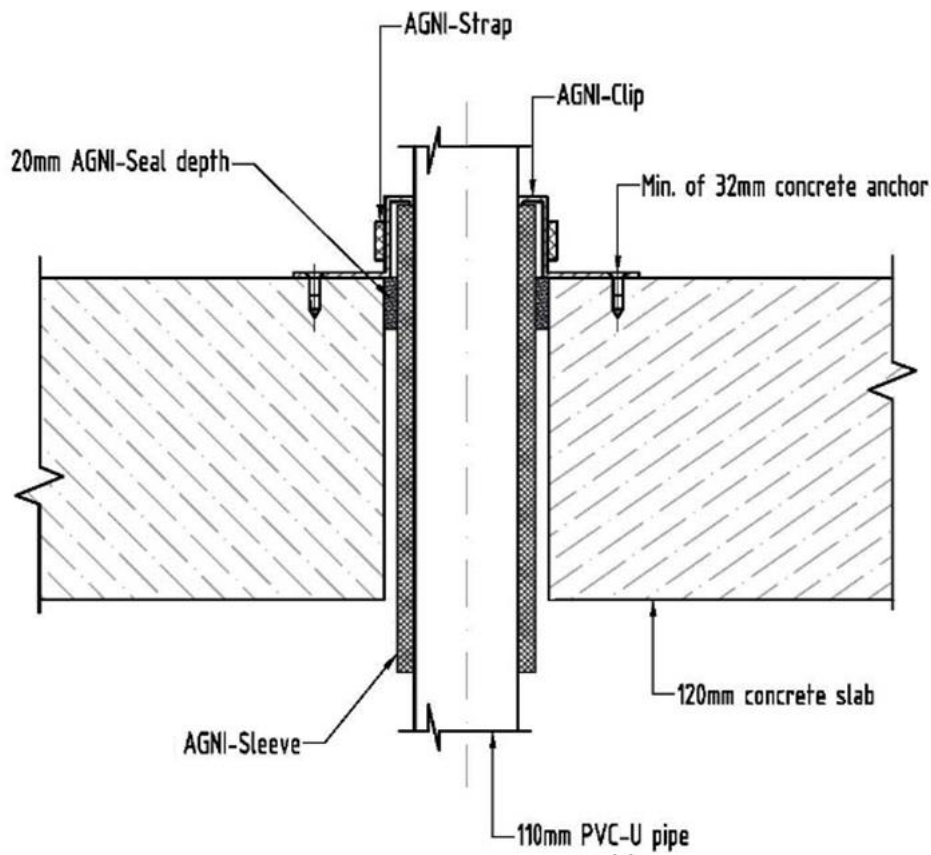

Figure 11 – Specimen 5

Service penetration details	
Service	DN100 PVC-U DWV Pipe
Service Support	Unistrut structure at 525mm and 1525mm
Aperture Diameter	130mm
Annular Spacing	Min: 8.5mm, Max: 11mm

Local Fire-stopping system	
Application	Asymmetrical
System description	AGNI-Sleeve positioned in annular space against the aperture perimeter with no overlap, extended 25mm from separating element. The Sleeve was secured by a cable tie penetrated the Sleeve and fixed with 2 screws and 2 clips on the unexposed side of separating element. AGNI-Seal sealed any gap

	between pipe, AGNI-Sleeve and separating element, from unexposed side of separating element.
--	--

---

**Test results**

Structural adequacy	Not applicable
Integrity	No failure at 124 minutes
Insulation	No failure at 124 minutes



## 5.6 Specimen 6

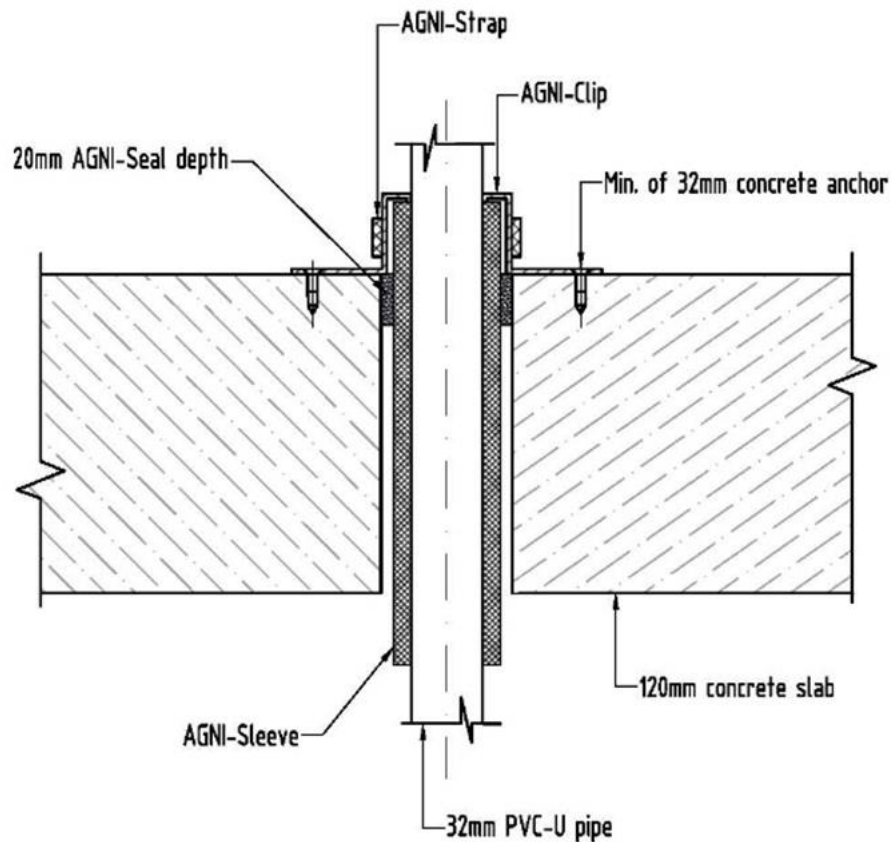

**Figure 13 – Specimen 6**

<b>Service penetration details</b>	
Service	DN32 PVC-U DWV Pipe
Service Support	Unistrut structure at 525mm and 1525mm
Aperture Diameter	46mm
Annular Spacing	Min: 4.5mm, Max: 5mm

<b>Local Fire-stopping system</b>	
Application	Asymmetrical
System description	AGNI-Sleeve positioned in annular space against the aperture perimeter with no overlap, extended 25mm from separating element. The Sleeve was secured by a cable tie penetrated the Sleeve and fixed with 2 screws and 2 clips on the unexposed side of separating element. AGNI-Seal sealed any gap

	between pipe, AGNI-Sleeve and separating element, from unexposed side of separating element.
--	--

---

**Test results**

Structural adequacy	Not applicable
Integrity	No failure at 124 minutes
Insulation	No failure at 124 minutes



## 5.7 Specimen 7

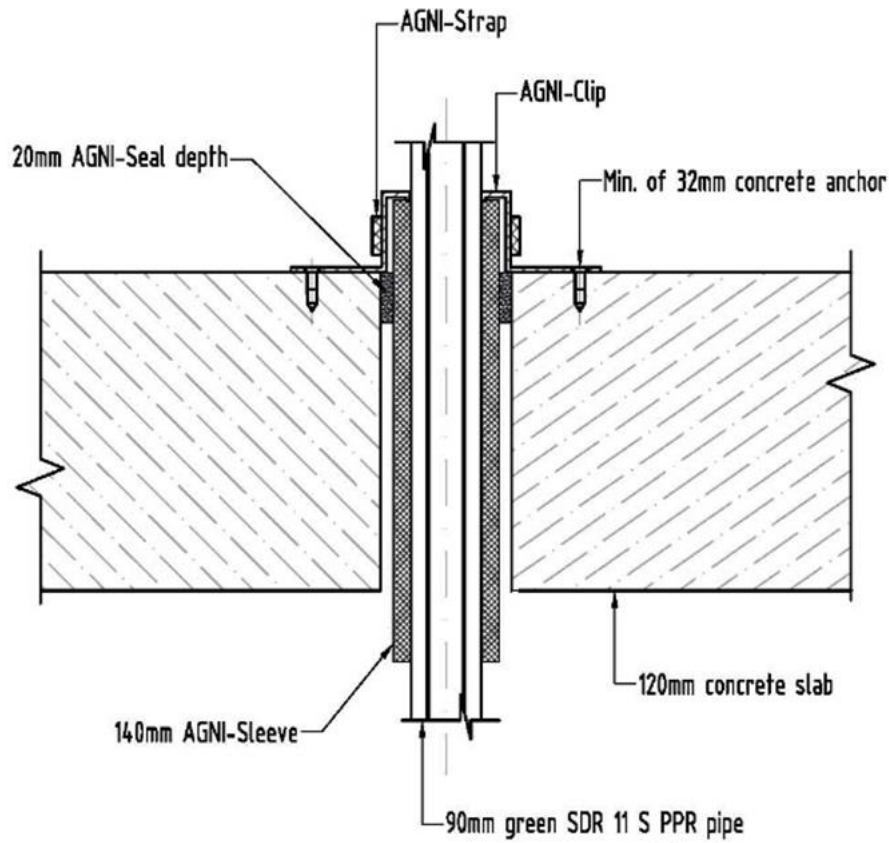

**Figure 15 – Specimen 7**

<b>Service penetration details</b>	
Service	90mm green SDR 11 S PPR pipe
Service Support	Unistrut structure at 525mm and 1525mm
Aperture Diameter	112mm
Annular Spacing	Min: 10mm, Max: 12mm

<b>Local Fire-stopping system</b>	
Application	Asymmetrical
System description	AGNI-Sleeve positioned in annular space against the aperture perimeter with no overlap, extended 25mm from separating element. The Sleeve was secured by a cable tie penetrated the Sleeve and fixed with 2 screws and 2 clips on the unexposed side of separating element. AGNI-Seal sealed any gap

	between pipe, AGNI-Sleeve and separating element, from unexposed side of separating element.
--	--

---

**Test results**

---

Structural adequacy	Not applicable
Integrity	No failure at 124 minutes
Insulation	No failure at 124 minutes





## 5.8 Specimen 8

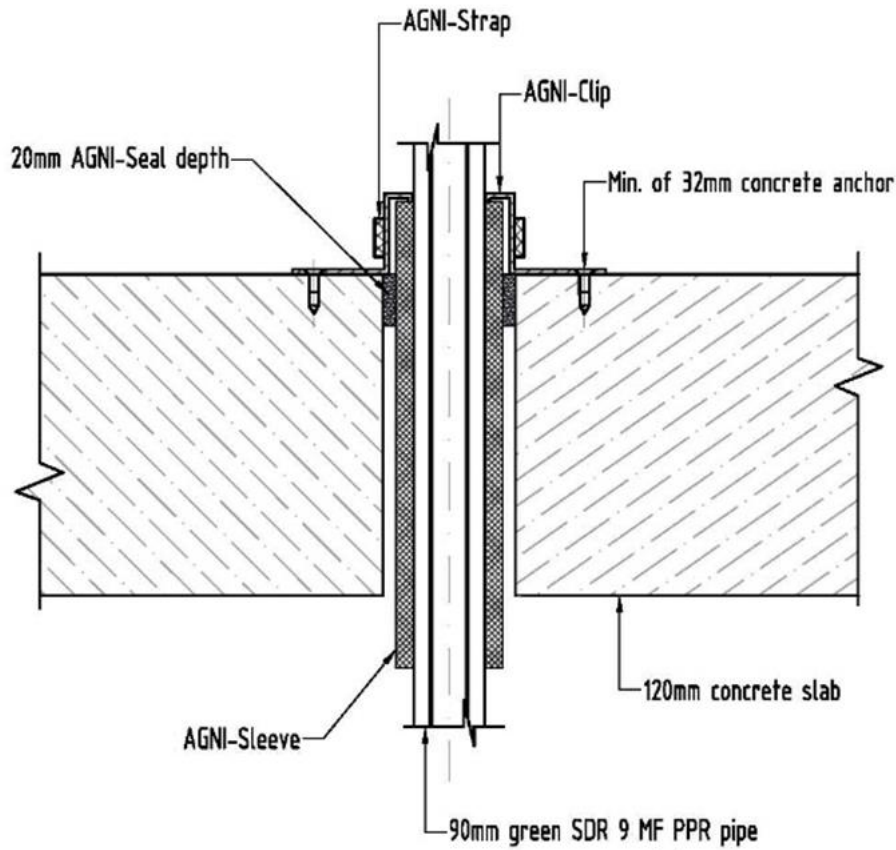

Figure 17 – Specimen 8

Service penetration details	
Service	90x10.1mm green SDR 9 MF RP pipe
Service Support	Unistrut structure at 525mm and 1525mm
Aperture Diameter	112mm
Annular Spacing	Min: 10mm, Max: 12mm

Local Fire-stopping system	
Application	Asymmetrical
System description	AGNI-Sleeve positioned in annular space against the aperture perimeter with no overlap, extended 25mm from separating element. The Sleeve was secured by a cable tie penetrated the Sleeve and fixed with 2 screws and 2 clips on the unexposed side of separating element. AGNI-Seal sealed any gap

	between pipe, AGNI-Sleeve and separating element, from unexposed side of separating element.
--	--

---

**Test results**

---

Structural adequacy	Not applicable
Integrity	No failure at 124 minutes
Insulation	No failure at 124 minutes

---



## 5.9 Specimen 9

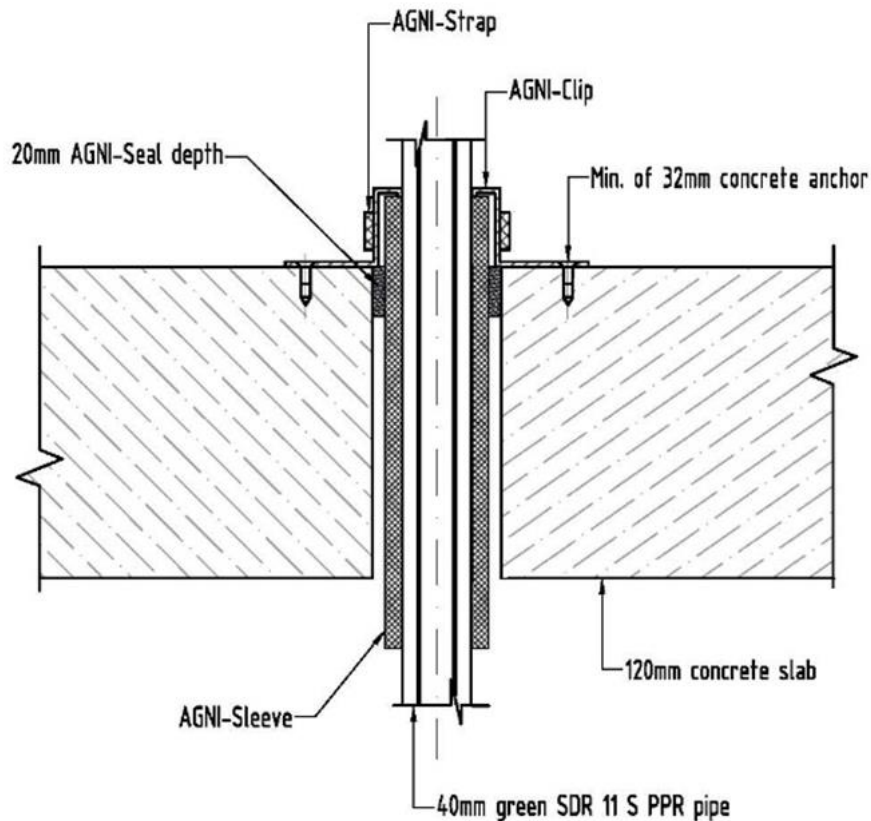

Figure 19 – Specimen 9

Service penetration details	
Service	40mm green SDR 11 S PPR pipe
Service Support	Unistrut structure at 525mm and 1525mm
Aperture Diameter	57mm
Annular Spacing	Min: 7.5mm, Max: 9.5mm

Local Fire-stopping system	
Application	Asymmetrical
System description	AGNI-Sleeve positioned in annular space against the aperture perimeter with no overlap, extended 25mm from separating element. The Sleeve was secured by a cable tie penetrated the Sleeve and fixed with 2 screws and 2 clips on the unexposed side of separating element. AGNI-Seal sealed any gap

	between pipe, AGNI-Sleeve and separating element, from unexposed side of separating element.
--	--

---

**Test results**

---

Structural adequacy	Not applicable
Integrity	No failure at 124 minutes
Insulation	No failure at 124 minutes

---



## 6. Observations during the test

---

Time min	Test face	SP#	OBSERVATIONS/REMARKS
			No significant observations during the test
124			Test Discontinued

**NOTE:** E - Exposed Face (inside furnace)  
U - Unexposed Face (outside furnace)  
SE - Separating element

## 7. Photos

---

### 7.1 Photos before and after the test

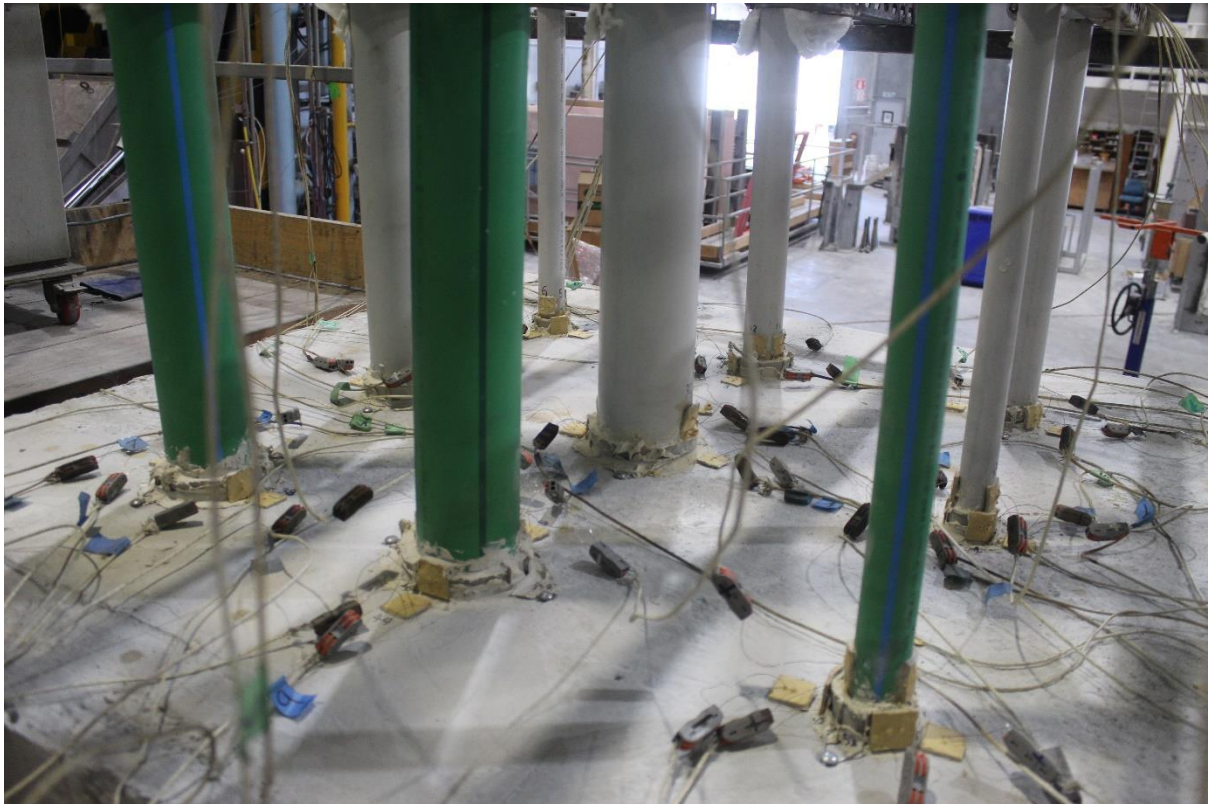

**Figure 21 – Unexposed face prior to test commencement**



**Figure 22 – Exposed face prior to test commencement**



**Figure 27 – Exposed face after the test**